

The DIGITAL plus locomotive decoder LE1035 is suitable for all DC motors in HO scale locomotives with continuous current draw of 1.0 Amp. or less. The characteristics of the decoder are:

- * Super smooth and silent high frequency back-emf motor control.
- * Adjustable precision stopping control
- * Low speed gear for switching operations
- * Selectable for operation with 14/27, 28/55 or 128 speed steps.
- * Operation on conventional DC layouts is possible or can be disabled.
- * Provides 1A continuous motor current.
- * Four on/off function outputs (outputs A and B rated at 150mA each, outputs C and D rated at 400mA each).
- * Directional or independent lighting with dimming.
- * Support for Advanced Consist Control and Extended Addressing
- * Support for programming on the mainline (operations mode programming)
- * Support for all form of programming as described in NMRA RP-9.2.3
- * Programmable locomotive address, acceleration and braking momentum, and much more.
- * Size: L 0.85" x W 0.65"x H 0.26" L 21.5mm x W 16.5 mm x H 6.6mm

LE1035-JST

Silent-Back EMF DCC Decoder

Art. No. 10332
December 2003

Digital

plus
by Lenz®

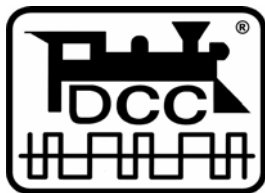

Submitted to the NMRA
for C&I testing

The features of the LE1035 Decoder

The LE1035 is designed to fully conform to all NMRA DCC standards and recommended practices. This ensures that the decoder will work properly on any NMRA DCC system.

The LE1035 is a high precision silent back emf decoder with 4 function outputs, independent or directional lighting effects that can be dimmed using a function, advanced consist control, extended addressing, operations mode programming and outstanding 128 step motor control. The LE1035 also supports all forms of programming described in NMRA Recommended Practice 9.2.3, including the user friendly direct CV programming mode.

DIGITAL plus decoders built to the NMRA standards and recommended practices are labeled:

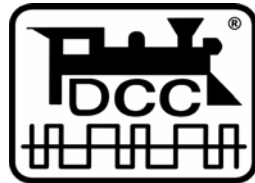

This prestigious label means that the NMRA has tested this product and found that it fully complies with all NMRA DCC Standards, Recommended Practices and industry norms. The LE1035 decoder was been submitted to the NMRA's C&I committee for independent testing.

Many characteristics of the LE1035 decoder can be programmed to customize the decoder to its locomotive. For example, you can operate the decoder with the factory pre-set speed table or generate your own. You can set which end of the locomotive is the forward end. You can even decide whether or not you want to be able to operate on conventional DC layouts.

Please read "Programming the LE1035 locomotive decoder" found later in this booklet for details on the configuration variables supported by the LE1035. There you will find much more information regarding the features and their respective settings.

High Frequency Back EMF Control

The LE1035 uses a form of motor control called "back emf" control. All DC motors produce a small amount of current when they are rotating. The amount of current produced is a function of the load that the motor is controlling. The LE1035 measures this current and is able to adjust the current to the motor based upon the motor load. The result is exceptionally fine motor control that is extremely smooth and quiet.

The LE1035 employs the finest motor control possible. It is suitable for all forms of motors including coreless motors.

Low gear operation

The LE1035 has two internal speed tables. When F3 is set (configurable using CV59) a low gear option is enabled.

Constant braking distance

Whenever the speed of the locomotive is set to zero (e.g. by moving the speed-knob to the left limit-stop), the locomotive/train covers a settable, defined braking distance before stopping. This braking distance does not depend on the speed of the locomotive/train.

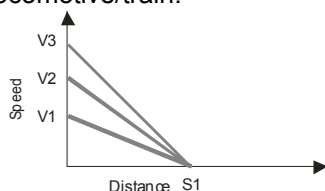

low value in CV61

A low value in CV61 results in a short braking distance, independent of the speed (V1, V2, V3).

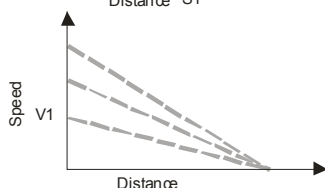



high value in CV61

A high value in CV61 results in a long braking distance, independent of the speed (V1, V2, V3).

Setting the constant braking distance:

The braking distance is defined by the value set in CV61. Since the motors and gear ratios of locomotives vary, the braking distance differs from locomotive to locomotive even if the same value is set in CV61.

1. Use a short test section to measure how long your locomotive's braking distance will be with a given value set in CV61. Start with the default value (100) in CV61.
2. First, enable the constant braking distance function (this requires setting Bit 2 in CV50). If this Bit is not set, the decoder will use the braking delay set in CV4.
3. Accelerate your locomotive until it has reached a speed in the middle of its speed range.
4. At a chosen point in time, set the speed to 0. This requires moving the -knob of the handheld LH30, LH90 or the *compact* to the left limit-stop; if you are using the LH100, keep pressing key  until the speed is set to 0 or until the locomotive address is displayed (if using the LH100, do not press the  key! This results in a locomotive-specific emergency stop and the delays in the locomotive decoder will not be enabled!). You can also use the center position of the LH90 direction switch to enable the braking operation.
5. Measure the covered braking distance.
6. Increase or decrease the value in CV61, e.g. in steps of 10, and carry out another measurement. You will thus create a table which will show the braking distances in relation to the values set in CV61.

Important advice:

The constant braking distance is only effective if the speed step is set to 0. If the speed step is decreased from e.g. 28 to 10, the braking delay using CV4 becomes effective.

While the low gear is switched off (function F3 off, see CV 59) the constant braking distance is disabled and the delay from CV4 becomes effective.

The constant braking distance is also disabled, if the braking delay disable function is turned on (function F4 on, see CV60)

The two latter features can be also used if you wish to interrupt a current braking operation.

The constant braking distance does not work for DC brakes.

Preparing to Install the LE1035

A locomotive that runs well under DC will run exceptionally well under DCC. Replace worn out motor brushes and burned out light bulbs. Clean any dirt or oxidation from the wheels and pickups, and make sure that electrical contact is good. Now is also a good time to lubricate your locomotive.

An internal rectifier supplies the current for all the decoder outputs with a maximum current rating of 1.0 Amps. The sum of the current to the motor and the function outputs cannot exceed this limit. Each individual output can only draw up to its limit.

Example:

Suppose the motor may require as much as 0.8 A continuously. Then the function outputs combined must not exceed 0.2 A. If the directional headlights require 50 mA each, then the load on outputs C and D must not exceed 150 mA.

Some advice on installing the decoder:

Although the LE1035 has many internal safeguards to prevent damage, you must not allow any metal part of the locomotive to touch the surface components of the decoder. This could cause a direct internal short circuit and the decoder will be destroyed. **The motor brushes MUST also be completely isolated from the rail pickup.** Achieving isolation may require some different approaches on different locomotives, perhaps unsoldering wires or placing a thin piece of insulating plastic between the motor and the locomotive frame. If you have a VOM, check for infinite resistance between the motor and all the wheels. Take special note that a short might occur when the loco body is reinstalled.

DO NOT WRAP decoder with electrical tape or shrink wrap!

Doing so will impede air circulation and degrade the performance of the decoder. Instead, put electrician tape over any part of the locomotive frame or body that might touch the decoder and use double sided foam mounting tape to mount the decoder. This will prevent short circuits without 'suffocating' the decoder.

The LE1035 can not be set up for simultaneous use for 2-rail pickup and overhead cantenary or trolley operation. If the locomotive is turned the wrong way, the decoder could get twice the track voltage, which would destroy it!

Wiring Options

There are two wiring options for installing the LE1035, depending on how the locomotive is constructed. The functions could be connected with their common to the decoders floating common (blue wire) as shown below or one rail can be used as a common. A mixture of both options is also possible.

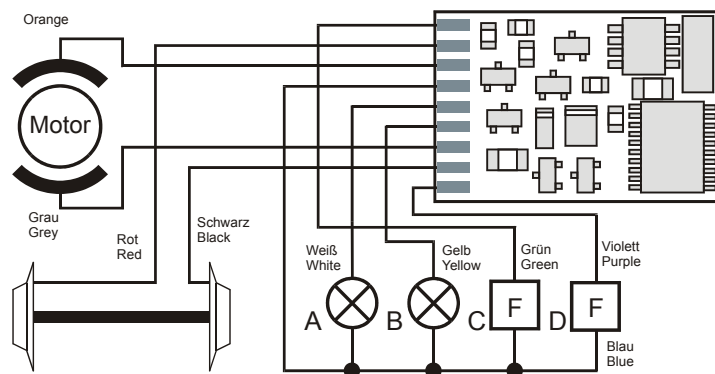

If the bulbs for the directional headlights are floating (isolated against wheel pick up and chassis) and connected according to above figure, they will shine brighter compared to using the rail as a common and the directional headlights will function while operating on conventional DC layouts.

Step by Step Installation

If the locomotive has a NMRA JST decoder socket simply remove the dummy plug on locomotive and plug in the decoder

If the locomotive has a NMRA 8 pin socket and the decoder has a 8 pin NMRA medium plug harness simply remove the dummy plug from the locomotive and plug in the decoder. The following instructions apply if you need to install the wired version.

Two wires connect the decoder to the motor. Make sure that the motor is electrically isolated from both track pickups:

- Orange wire to the motor terminal that was previously connected to the right rail (Pin #1).
- Gray wire to the motor terminal that was previously connected to the left rail (Pin #5).



Two wires connect the decoder to the track electrical pickups:

- Red wire to right rail pickup (Pin #8).
- Black wire to the left rail pickup (Pin #4).

Five wires connect the headlights and functions to the decoder:

- White wire (Pin #6) to the forward headlight or the function controlled by Output A. If the bulb is isolated, connect the blue wire (Pin #7) to the other terminal.
- Yellow wire (Pin #2) to the rear headlight or the function controlled by Output B. If the bulb or function is isolated, then connect the blue wire (Pin #7) to the other terminal.
- Green wire (Pin #3) to function controlled by Output C. If the bulb is isolated, connect the blue wire (Pin #7) to the other terminal.
- Violet wire to function controlled by Output D. If the bulb is isolated, connect the blue wire (Pin #7) to the other terminal.

Place the locomotive (without its shell) on the programming track and read back the locomotive's address from the decoder. If the decoder is properly installed, you will be able to read back the factory pre-set address 03. Remove the locomotive from the track, and if necessary correct any wiring errors.

Programming the locomotive decoder LE1035

The LE1035 supports all NMRA DCC programming modes and can be programmed by any NMRA DCC programmer. With some entry level systems only a few CVs (such as CV #1, the locomotive address) can be set unless you use a separate programmer. Specific details for reading and writing the decoder's configuration variables can be found in the manuals of the appropriate equipment used for programming.

The configuration variables and their meaning

The following table lists the various CVs supported in the LE1035 decoder. Both the NMRA DCC CV numbers and the older Register numbers are provided for cross reference.

Please note: Some CVs (such as CV29) have specific meanings for each bit. The bit assignments in this table use a bit numbering scheme of 0-7 to correspond the NMRA convention for universal bit numbering. Many handhelds (such as the DIGITAL plus

handhelds) use a scheme of 1-8 to refer to the individual bits rather than 0-7. (Bit 0 in this table is displayed as a "1" on LH100 handheld, Bit 1 is identified as "2".) The bit numbers in () within these tables contain the LH100 bit numbers.

Table 1: LE1035 Configuration Variables

CV	Reg	Description	Range	Factory setting
1	1	Locomotive short address: This is the number used to operate your locomotive. Digital plus by Lenz® systems restrict the range of this CV to be from 1-99. Larger numbers are considered Extended Addresses. When this CV is written, the decoder clears CV19 (the consist address) and sets the extended address bit in CV29 is set have a value of 0.	1-127	3
2	2	Start voltage: The LE1035 automatically adjusts the internal start voltage to be the minimum speed of the motor/drive train combination where a back-emf signal can be determined. This results in a smooth and quiet starting speed.	0	0
3	3	Acceleration Momentum: Determines the rate of change of speed upon acceleration. A higher value leads to a slower acceleration.	1-255	4
4	4	Brake Momentum: Determines the rate of change of speed upon braking. A higher value leads to longer brake distance.	1-255	4
5	-	Maximum speed Determines the maximum speed that the locomotive will move. This allows you to operate your locomotives in a prototypical speed range. (only active if back EMF enabled)	2-10	10
-	5	Contains CV29 (see CV29 below)	0-55	6
-	6	Page/Pointer Register: Normally this CV is not modified directly by a user. For correct operation, this CV should be set to have a value of 1 after any use.	0-127	1
7	7	Version Number: This location stores the version number of the decoder. This location is read only.	-	1
8	8	Manufacturers Identification: Contains the manufacturer ID of the decoder, (Lenz =99). Writing a value of 33 using Register mode resets all CVs to their factory condition	-	99

**Note: in the factory setting field the numbers in the [] are decimal.

CV	R	Description	Range	Setting
17	-	Extended Address High Byte	192-231	0
18	-	Extended Address Low Byte The two byte address if used is contained in CV17+18	0-255	0
19	-	Consist Address The advanced consist address if used is stored in CV19	0-255	0
29	5	Decoder Configuration, Byte 1: Several decoder properties are set with this byte. Changes are best done in binary mode (see the information for the Hand Held LH100). The detailed properties are:	0-63	6
	bit 0 (1)	Locomotive direction: Locomotive's relative direction: This bit sets the direction the locomotive will move when told to move forward in digital mode. 0 = locomotive's direction is normal 1 = locomotive's direction is reversed	0,1	0 [1]
	bit 1 (2)	Headlight mode: 0 = Operation with 14 or 27 speed step systems. This setting is selected when the locomotive decoder is used with any Digital system that does not support 28 speed step mode. If the headlights turn on and off as the speed is increased, the command station is configured for 28 speed step mode, and the decoder is in 14 speed step mode. 1 = Operation with 28, 55 or 128 speed steps. If you use this setting, the Command Station must also be configured to use 28 speed step mode or 128 speed step mode for the decoder's address, otherwise the headlights can not be controlled.	0,1	1 [2]
	bit 2 (3)	Usage on conventional DC layouts: 0 = locomotive operates in digital mode only 1 = locomotive can operate on either conventional DC and on DCC	0,1	1 [4]
	bit 3 (4)	Enable RailCom (not available)	*	0
	bit 5 (6)	Extended Addressing 0= Normal addressing 1= Four digit extended addressing	0-1	0 [32]
	bit 6 bit 7	always 0	0	0

CV	Description	Range	Setting
50	Decoder Configuration, byte 2: Similar to CV 29, but other properties are set with this byte:	0-7	1
bit 0 (1)	Not Used		1 [1]
bit 1	Braking Action 0= speed dependent braking not active 1= speed dependent braking is active	0,1	0 [2]
bit 2 (3)	Brake momentum on DC operation. Used to achieve prototypical braking at red signal indications if conventional DC control CV29.2 is disabled. (CV 29 bit 2 = 0) 0 = locomotive proceeds with track voltage dependent speed inside the conventional DC section. 1 = locomotive brakes in the conventional DC section with pre set brake momentum.	0,1	0 [4]
bits 4-8	not used		
51	Lighting Effects for Outputs A and B	0-15	0
bit 0 (1)	0 = the headlights (A&B) are directional. 1 = the lights (A&B) are independent per Rule 17. F0 controls the front headlight and F1 the rear headlight or a separate function.	0,1	0 [1]
bit 1 (2)	Only active if bit 2 (3) is set to a value of 1 0 = function A output is always dimmed 1 = the value in CV52 is used for headlight/function dimming. If directional F1 is used for dimming, if independent F4 is used for dimming	0,1	0 [2]
bit 2 (3)	Output A can be dimmed	0,1	0 [4]
bit 3(4)	Output B can be dimmed	0,1	0 [8]
bits 4-7	Not used		
54	Function assignment for Output C	0-255	1
bit 0 (1)	1 = Output C is controlled By F1	0,1	1 [1]
bit 1 (2)	1 = Output C is controlled By F2	0,1	0 [2]
bit 2 (3)	1 = Output C is controlled By F3	0,1	0 [4]
bit 3 (4)	1 = Output C is controlled By F4	0,1	0 [8]
bit 4 (5)	1 = Output C is controlled By F5	0,1	0 [16]
bit 5 (6)	1 = Output C is controlled By F6	0,1	0 [32]
bit 6 (7)	1 = Output C is controlled By F7	0,1	0 [64]
bit 7 (8)	1 = Output C is controlled By F8	0,1	0 [128]

CV	Description	Range	Setting
55	Function assignment for Output D	0-255	2
	bit 0 (1) 1 = Output D is controlled By F1	0,1	1 [1]
	bit 1 (2) 1 = Output D is controlled By F2	0,1	0 [2]
	bit 2 (3) 1 = Output D is controlled By F3	0,1	0 [4]
	bit 3 (4) 1 = Output D is controlled By F4	0,1	0 [8]
	bit 4 (5) 1 = Output D is controlled By F5	0,1	0 [16]
	bit 5 (6) 1 = Output D is controlled By F6	0,1	0 [32]
	bit 6 (7) 1 = Output D is controlled By F7	0,1	0 [64]
	bit 7 (8) 1 = Output D is controlled By F8	0,1	0 [128]
59	Function Mapping for switching gear	0-255	4
	bit 0 (1) 1 = switching gear is controlled By F1	0,1	1 [1]
	bit 1 (2) 1 = switching gear is controlled By F2	0,1	0 [2]
	bit 2 (3) 1 = switching gear is controlled By F3	0,1	0 [4]
	bit 3 (4) 1 = switching gear is controlled By F4	0,1	0 [8]
	bit 4 (5) 1 = switching gear is controlled By F5	0,1	0 [16]
	bit 5 (6) 1 = switching gear is controlled By F6	0,1	0 [32]
	bit 6 (7) 1 = switching gear is controlled By F7	0,1	0 [64]
	bit 7 (8) 1 = switching gear is controlled By F8	0,1	0 [128]
60	Function Mapping for disabling the braking delay	0-255	8
	bit 0 (1) 1 = braking delay is controlled By F1	0,1	1 [1]
	bit 1 (2) 1 = braking delay is controlled By F2	0,1	0 [2]
	bit 2 (3) 1 = braking delay is controlled By F3	0,1	0 [4]
	bit 3 (4) 1 = braking delay is controlled By F4	0,1	0 [8]
	bit 4 (5) 1 = braking delay is controlled By F5	0,1	0 [16]
	bit 5 (6) 1 = braking delay is controlled By F6	0,1	0 [32]
	bit 6 (7) 1 = braking delay is controlled By F7	0,1	0 [64]
	bit 7 (8) 1 = braking delay is controlled By F8	0,1	0 [128]
61	Constant Braking Distance. Sets the distance that the locomotive will stop during a constant distance braking operation. If set to 0 the breaking distance feature is disabled	0-255	100
128	Decoder Software Version – read only		05

North American Warranty

Lenz GmbH does everything it can do to ensure that its products are free from defects and will operate for the life of your model railroad equipment. From time to time even the best engineered products fail either due to a faulty part or from accidental mistakes in installation. To protect your investment in Digital plus products, Lenz GmbH offers a very aggressive 10 year Limited Warranty.

This warranty is not valid if the user has altered, intentionally misused the Digital Plus product, or removed the product's protection, for example the heat shrink from decoders and other devices. In this case a service charge will be applied for all repairs or replacements. Should the user desire to alter a Digital Plus Product, they should contact Lenz GmbH for prior authorization.

Year One: A full repair or replacement will be provided to the original purchaser for any item that that has failed due to manufacturer defects or failures caused by accidental user installation problems. Should the item no longer be produced and the item is not repairable, a similar item will be substituted at the manufacturer's discretion. The user must pay for shipping to an authorized Lenz GmbH warranty center.

Year 2 and 3: A full replacement for any item will be provided that has failed due to manufacturer defects. If the failure was caused by accidental user installation or use, a minimal service charge may be imposed. Should the item no longer be produced and the item is not repairable, a similar item will be substituted at the manufacturer's discretion. The user must pay shipping to and from the authorized Lenz GmbH warranty center during this portion of the warranty period.

Year 4-10: A minimal service charge will be placed on each item that has failed due to manufacturer defects and/or accidental user installation problems. Should the item no longer be produced and the item is not repairable, a similar item will be substituted at the manufacturer's discretion. The user must pay shipping to and from the authorized Lenz GmbH warranty center during this portion of the warranty period.

Please contact your dealer or authorized Lenz GmbH warranty center for specific instructions and current service charges prior to returning any equipment for repair.

Hüttenbergstraße 29
35398 Gießen, Germany
Hotline: 06403 900 133
Fax: 06403 900155
info@digital-plus.de

Lenz
ELEKTRONIK GMBH
<http://www.lenz.com>

Lenz Agency of North America
PO Box 143
Chelmsford, MA 01824
ph: 978 250 1494
fax: 978 455 LENZ
support@lenz.com

This equipment complies with Part 15 of FCC Rules. Operation is subject to the following two conditions: (1) this device may not cause harmful interference, and (2) this device must accept any interference received, including interference that may cause undesired operation.

 Please save this manual for future reference!

© 2003 Lenz GmbH, All Rights Reserved